



|          |                              |          |
|----------|------------------------------|----------|
| SM 2018  |                              | Form A   |
| Pilot ID | CIVA Intermediate Free Known | Flight # |

| No | Symbol | Cat. No.                                  | K                 | Total K     | Marks | Remarks | Pos | Item                   | K   | Grade   |
|----|--------|---|-------------------|-------------|-------|---------|-----|------------------------|-----|---|
| 1  |        | 1.1.2.1<br>9.2.2.4                        | 7<br>11           | 18          |       |         |     | Pos.                   | 30  | <div style="border: 2px solid black; width: 40px; height: 20px;"></div> |
| 2  |        | 8.6.4.3<br>9.11.1.4<br>9.1.3.1<br>9.1.3.3 | 13<br>5<br>2<br>6 | Fig D<br>26 |       |         |     | Fig K                  | 200 | Total K<br>230  |
| 3  |        | 7.3.3.3<br>9.4.4.2                        | 14<br>5           | 19          |       |         |     | <b>Penalties</b>       |     |   |
| 4  |        | 5.2.1.1<br>9.8.1.1<br>9.1.5.2             | 17<br>7<br>4      | Fig B<br>28 |       |         |     | Too Low                |     |   |
| 5  |        | 8.4.1.1<br>9.1.1.1                        | 13<br>6           | Fig A<br>19 |       |         |     | Too High               |     |   |
| 6  |        | 7.3.2.1<br>9.4.2.2                        | 14<br>7           | Fig C<br>21 |       |         |     | Interruptions          |     |   |
| 7  |        | 1.1.1.1<br>9.9.3.4                        | 2<br>11           | 13          |       |         |     | Insertions             |     |   |
| 8  |        | 7.2.3.3<br>9.4.3.2                        | 6<br>5            | 11          |       |         |     | Trg Violation          |     |   |
| 9  |        | 1.2.6.1                                   | 14                | 14          |       |         |     | Wing Rocks             |     |   |
| 10 |        | 7.2.1.1<br>9.2.3.4                        | 6<br>9            | 15          |       |         |     | Disqual Fig            |     |   |
| 11 |        | 2.1.3.4                                   | 16                | Fig E<br>16 |       |         |     | Other(note...)         |     |   |
|    |        |   |                   |             |       |         |     | <b>Final Freestyle</b> |     |   |
|    |        |   |                   |             |       |         |     | Duration               | Min | Sec   |
|    |        |   |                   |             |       |         |     |                        |     |   |
|    |        |   |                   |             |       |         |     | <b>Judges Details</b>  |     |   |
|    |        |   |                   |             |       |         |     | Signature              |     |   |
|    |        |   |                   |             |       |         |     | Name                   |     |   |
|    |        |   |                   |             |       |         |     | Number                 |     |   |

\_\_\_\_\_ Pilot  
 ..... A/C



SM 2018

---

Pilot ID \_\_\_\_\_

CIVA Intermediate Free Known

Form B

---

Flight # \_\_\_\_\_

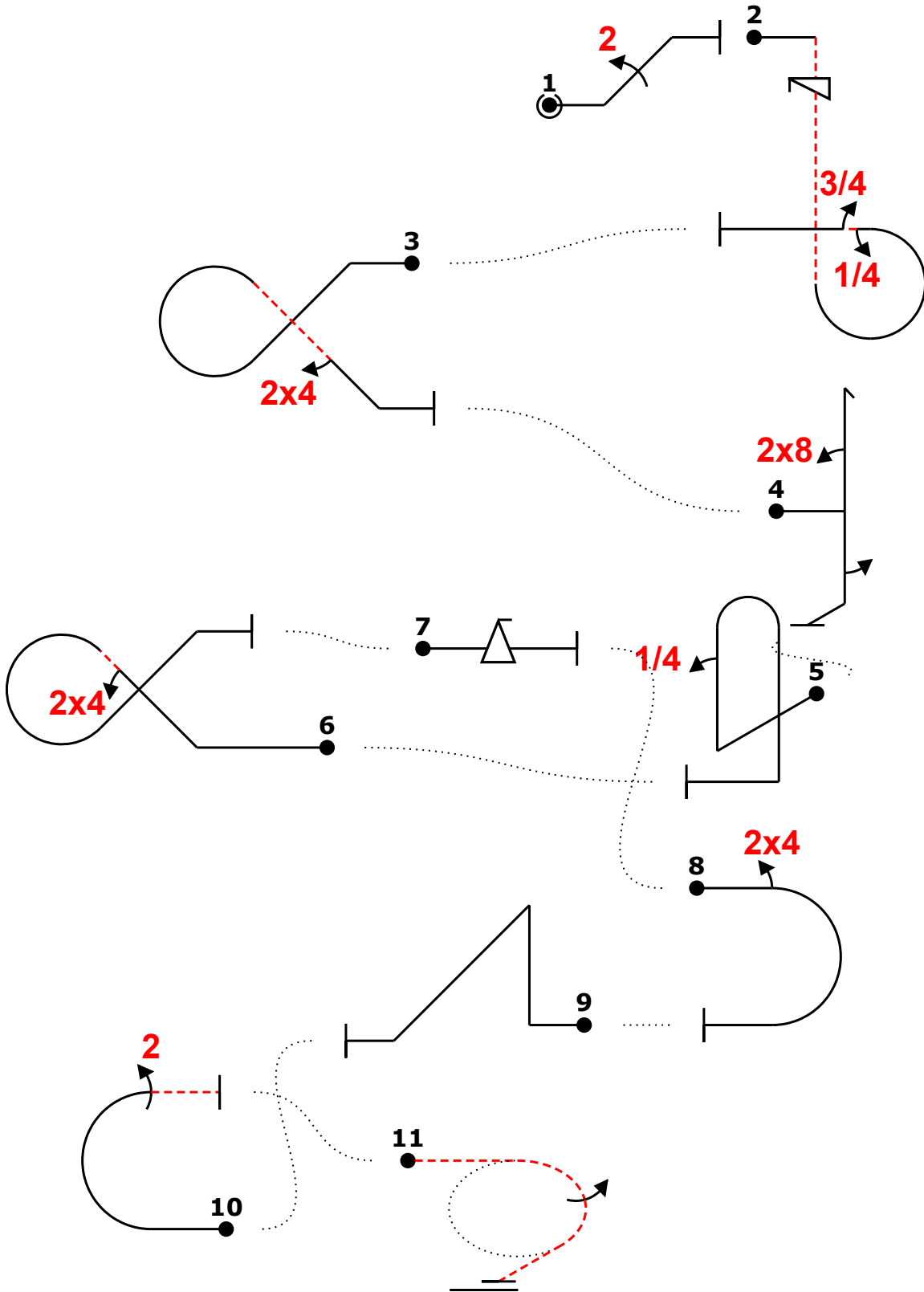
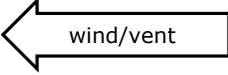

| Power                                 |   |                   |    |
|---------------------------------------|---|-------------------|----|
| Fig 1                                 | 1.1.2.1<br>9.2.2.4                        | 7<br>11           | 18 |
| Fig 2<br><b>D</b>                     | 8.6.4.3<br>9.11.1.4<br>9.1.3.1<br>9.1.3.3 | 13<br>5<br>2<br>6 | 26 |
| Fig 3                                 | 7.3.3.3<br>9.4.4.2                        | 14<br>5           | 19 |
| Fig 4<br><b>B</b>                     | 5.2.1.1<br>9.8.1.1<br>9.1.5.2             | 17<br>7<br>4      | 28 |
| Fig 5<br><b>A</b>                     | 8.4.1.1<br>9.1.1.1                        | 13<br>6           | 19 |
| Fig 6<br><b>C</b>                     | 7.3.2.1<br>9.4.2.2                        | 14<br>7           | 21 |
| Fig 7                                 | 1.1.1.1<br>9.9.3.4                        | 2<br>11           | 13 |
| Fig 8                                 | 7.2.3.3<br>9.4.3.2                        | 6<br>5            | 11 |
| Fig 9                                 | 1.2.6.1                                   | 14                | 14 |
| Fig 10                                | 7.2.1.1<br>9.2.3.4                        | 6<br>9            | 15 |
| Fig 11<br><b>E</b>                    | 2.1.3.4                                   | 16                | 16 |
| <b>Total K = 200</b><br>(max K = 200) |   |                   |    |

\_\_\_\_\_/ Pilot  
 ...../ A/C



|          |                              |          |
|----------|------------------------------|----------|
| SM 2018  |                              | Form C   |
| Pilot ID | CIVA Intermediate Free Known | Flight # |

